



上海永明机械制造有限公司



SHANGHAI YONGMING MACHINERY MANUFACTURING CO., LTD.

***Quotation of the metal
skinned heat-insulation
rock-cotton Sandwich Panel
Product Line(PRL-6-U)***

PRL-6-U 型金属隔热夹芯板生产线

Shanghai Yongming Machinery Manufacturing CO., LTD.

**Add: 138 CheTing road, Songjiang district Shanghai China ,
201611**

Fax:0086-21-57604676

Tel:0086-21-57604762

Shanghai Yongming Machinery Manufacturing Co., Ltd.(China)

Add: 138 Cheting road, Songjiang district Shanghai China, 201611

Tel: 0086-21-57604761 57604762

Fax:0086-21-57604676

www.sh-ym.com

E-mail: shanghaiyongming@126.com

yeminz@vip.sina.com



2 . The panel drawing of PRL-6-U making PRL-6-U 型设备板型图

1 . .wall panel 墙面板

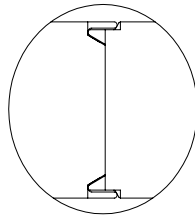
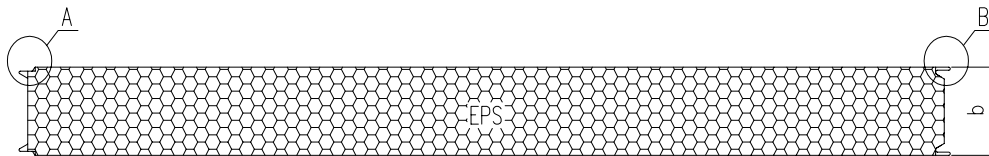

上钢板展开长度:1250mm The width of up steel sheet:1250mm

下钢板展开长度:1250mm. The width of bottom steel sheet:1250mm

b=50-150mm.

芯材: 聚苯乙烯 (EPS)或岩棉。 The core material: polystyrene foam or mineral wool

The sample:

样品照片



Shanghai Yongming Machinery Manufacturing Co., Ltd.(China)

Add: 138 Cheting road, Songjiang district Shanghai China, 201611

Tel: 0086-21-57604761 57604762

Fax:0086-21-57604676

www.sh-ym.com

E-mail: shanghaiyongming@126.com

yeminz@vip.sina.com



上海永明机械制造有限公司



SHANGHAI YONGMING MACHINERY MANUFACTURING CO., LTD.

2. .Cryptic wall panel 墙面板

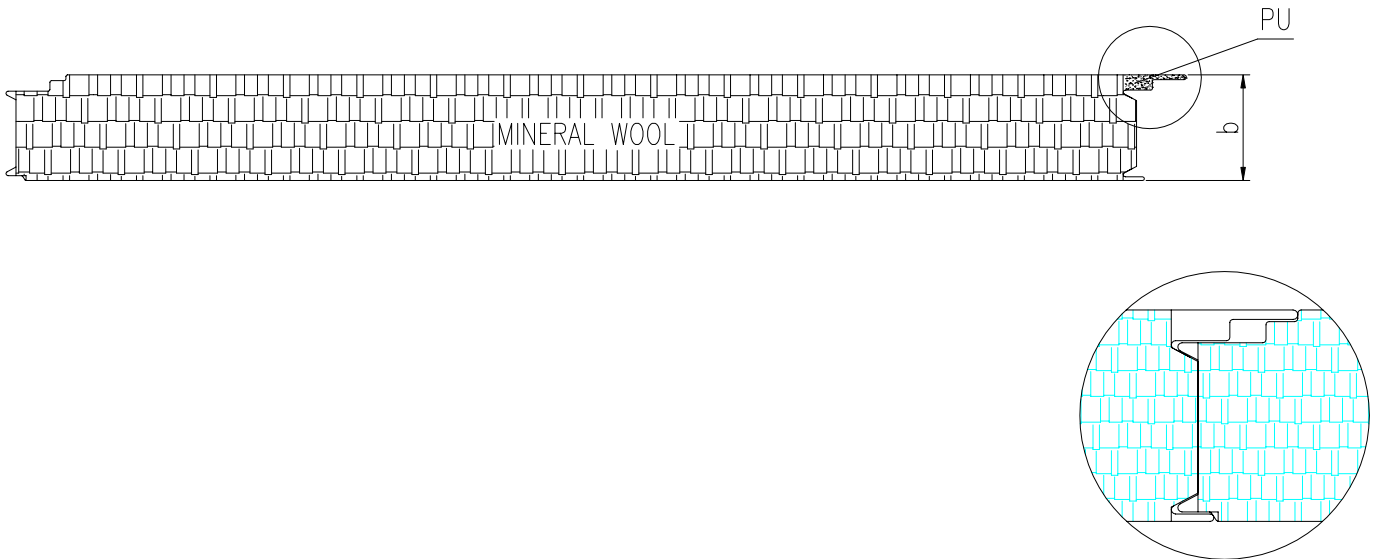

上钢板展开长度:1250mm.The width of up steel sheet is 1250mm
下钢板展开长度:1150mm.The width of bottom steel sheet is 1150mm
b=50-150mm.

芯材: 聚苯乙烯 (EPS)或岩棉.Core material:polystyrene foam or rock wool

Shanghai Yongming Machinery Manufacturing Co., Ltd.(China)

Add: 138 Cheting road, Songjiang district Shanghai China, 201611

Tel: 0086-21-57604761 57604762

Fax:0086-21-57604676

www.sh-ym.com

E-mail: shanghaiyongming@126.com

yeminz@vip.sina.com



2. .roof panel 屋面板

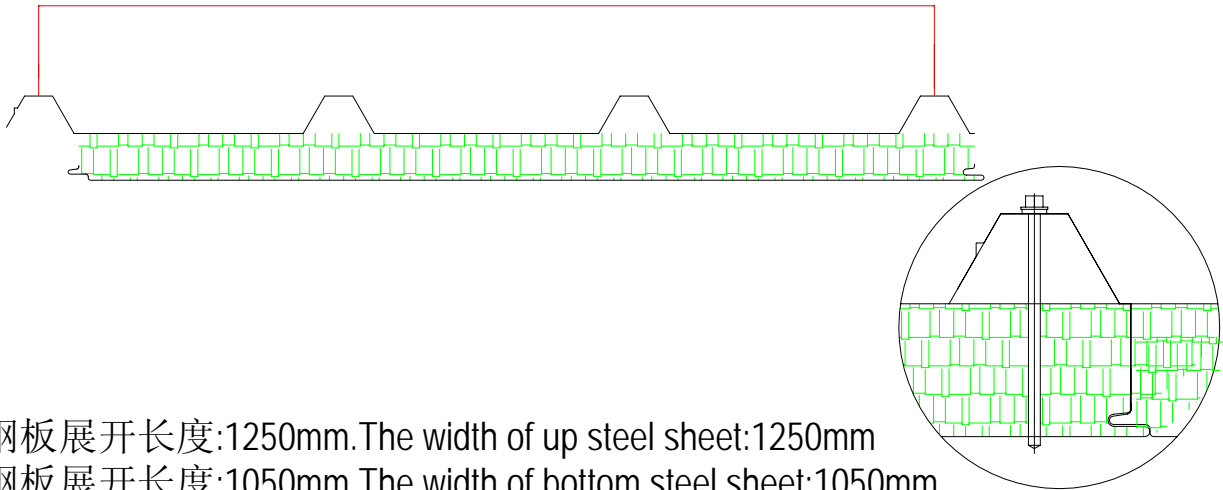

上钢板展开长度:1250mm.The width of up steel sheet:1250mm

下钢板展开长度:1050mm.The width of bottom steel sheet:1050mm

b=50-100mm.

芯材：聚苯乙烯（EPS)或岩棉。Core material:polystyrene foam or mineral wool



3 . Composing of product line:设备组成:

NO.	Composing of product line:组成	Amount 数目	Price(USD) FOB SHANGHAI 价格
1	Uncoiler (passive)开卷机.被动开卷	2	
2	Steel panel transverse cutting device, steel panel surface PVC film covering device 钢板覆膜,横切断装置	2	
3	Rockcotton automatically feeding system	1	
4	Roll forming machine 压型机	2	
5	Pre-heating room 预热房	1	
6	PU MIXING SPRAY MACHINE (low pressure pu foam) 聚氨酯发泡机	1	
7	Mainframe 层压机	1	
8	Sandwich panel automatically belt cutter.带锯切割机	1	
9	Automatic stack system	1	
10	Electric control system 电气控制系统	1	
◇	TOTAL(USD,FOB SHANGHAI)		450,000
◇	Production Cycle: 120 workdays		

Shanghai Yongming Machinery Manufacturing Co., Ltd.(China)

Add: 138 Cheting road, Songjiang district Shanghai China, 201611

Tel: 0086-21-57604761 57604762

Fax:0086-21-57604676

www.sh-ym.com

E-mail: shanghaiyongming@126.com

yeminz@vip.sina.com



The product line mainly consists of the following components:

设备主要组成:

1、Coil mandrel and Coil base frame: 开卷机和涨紧器

Specification: 规格

The quantity of Coil mandrel is 4, which could adapt for the inner diameter 508mm, the width is no more than 1300mm and weight is no more than 6000kg, The outside diameter is no more than 1300mm.

开卷位置有 3 个. 涨紧器 4 个. 适用于内径 508mm, 宽度小于 1300mm, 外径小于 1300mm, 重量小于 6 吨的彩钢卷.

2、the rock wool strip feeding machine

装机总容量: 20kw. Total power: about 20KW 该机器满足最大规格 1200MM*1200MM (长*宽)、厚度 50 mm、容重 100-200KG/M3 的岩棉分条输送; This machine could slit the rock wool slab which is 1200mm*1200mm(length*width), 50mm thickness to strip. Its density is 100-200kg/m3. The strip could be feed into the sandwich panel laminated machine.

The sketch of the machine

The rock wool strip feeding direction

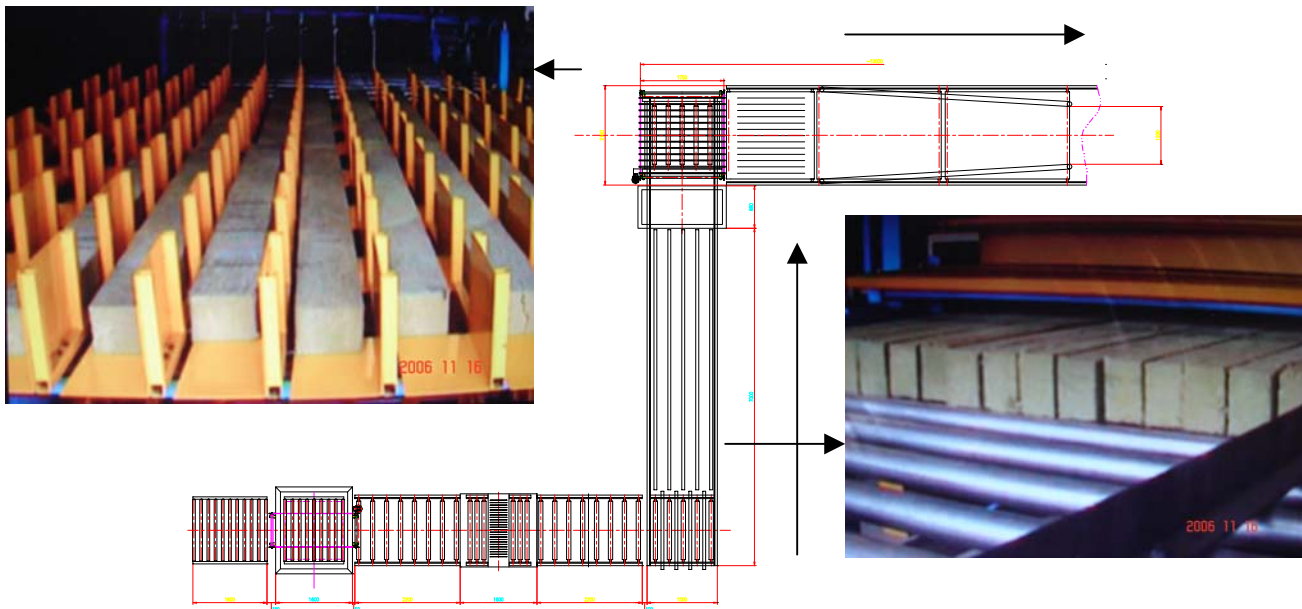

Shanghai Yongming Machinery Manufacturing Co., Ltd.(China)

Add: 138 Cheting road, Songjiang district Shanghai China, 201611

Tel: 0086-21-57604761 57604762

Fax:0086-21-57604676

www.sh-ym.com

E-mail: shanghaiyongming@126.com

yeminz@vip.sina.com



3. Two sets of Roll Former machine

Specification:

Roll Former machine 1: 8500mm*1520mm(length*width), the motor power is 4kw, corresponding panel is the NO. 3 of panel drawing ;

压型机 1: 尺寸: 长*宽 8500mm*1520mm. 电机 4kw, 如下左图:

Roll Former machine 2: 6500mm*1520mm(length*width), the motor power is 2.2kw, corresponding panel is the NO. 2 of panel drawing ;

压型机 2: 尺寸: 长*宽 6500mm*1520mm. 电机 2.2kw, 如下右图:



4. One set of Main body of the metal skinned heat-insulation mineral wool Sandwich Panel Product Line

Specification:

Shanghai Yongming Machinery Manufacturing Co., Ltd.(China)

Add: 138 Cheting road, Songjiang district Shanghai China, 201611

Tel: 0086-21-57604761 57604762

Fax: 0086-21-57604676

www.sh-ym.com

E-mail: shanghaiyongming@126.com

yeminz@vip.sina.com



Mainbody:15000mm*2200mm(length*width),
Up and bottom steel-panel machine 6000mm*2200mm (length*width),
laminating machine 8000mm*2200mm(length*width).

The main driven motor power is 3kw.

主机:尺寸:长*宽(15000mm*2200mm),由2段组成,主机功率 3 kw

5. PU glue low pressure mixing spray machine

聚氨酯发泡机

6. One set of cutting device:

Cutting machine can move longitudinally along product line;
Band saw of the cutting machine can move transversely, Cutting machine moves longitudinally and transversely. Cutting machine adopts one-side blade band saw manner, There is panel tight-pressing system (pneumatic) in the cutting machine; There is location limiter to limit longitudinal and transverse motion of cutting machine.

- **切割机:切割机可以沿生产线纵向方向移动,带锯刀可以横向移动,切割机采用单面刃带锯,有带锯涨紧装置,切割机设置板材压紧装置(气动),切割机纵向、横向移动装有限位装置**

7. Conveyer and automatic stack machine: The length of this section is about 20m, automatic stack machine is droved by pneumatic driving. And the roof panel could be turned 180 degree, then be automatic stack.

8. Electrical control device:

The machine is controlled by PLC (**MITSUBISHI JAPAN**) and touch screen(Pro-face JAPAN).

电器控制系统,采用 PLC 和触摸屏控制

- Requirement of workshop: 100m*18m*5.5m(length*width*height).

对厂房要求: 100m*18m*5.5m

- Primary technology parameters of PRL-6-U sandwich panel product line:

设备技术参数:

- Speed of product line: maximal speed: 4m/min(frequency conversion to adjust speed).
- **生产线传动速度: 最大速度 4m/min, 变频调速,**
- The dimension the product line: about 80 m*10m*2.3m
生产线尺寸: 80m*10m*2.3m

Shanghai Yongming Machinery Manufacturing Co., Ltd.(China)

Add: 138 Cheting road, Songjiang district Shanghai China, 201611

Tel: 0086-21-57604761 57604762

Fax:0086-21-57604676

www.sh-ym.com

E-mail: shanghaiyongming@126.com

yeminz@vip.sina.com



上海永明机械制造有限公司



SHANGHAI YONGMING MACHINERY MANUFACTURING CO., LTD.

- Total power of the product line: about 120 KW
总功率: 120kw
- Total weight is about 90 ton
总重量: 约 90 吨
- The transport

The product line need 9 40' container to transport.

运输:用 9 个 40 英尺集装箱.

- Payment terms:
30% for the down payment
70% the retentive payment shall be payoff before handing over of
the goods

付款方式:30%预付,70%在提货前付清

- The seller will finish manufacturing the Sandwich Panel Product Line
within 120 workdays after receiving the earnest.

交货期:收到预付款后 120 个工作日内交货

- Warranty: 12 months limited warranty

保修期:一年有限保修.

Shanghai Yongming Machinery Manufacturing Co., Ltd.(China)

Add: 138 Cheting road, Songjiang district Shanghai China, 201611

Tel: 0086-21-57604761 57604762

Fax:0086-21-57604676

www.sh-ym.com

E-mail: shanghaiyongming@126.com

yeminz@vip.sina.com